



FUGITIVE
EMISSIONS
EN-ISO 15848-1
TALUFT / VDI 2440

- Valve design: Reduced Bore API 6D
- Body design: ASME VIII Div.1
- Shell thickness: ASME B16.34
- Flanges: ASME B16.5 Raised Face
- Face to face dimensions: ASME B16.10 Short Pattern
- Marking: API 6D / CE - PED / MSS SP25
- Pressure testing: API 598 - API 6D
- Shell finishing quality: MSS SP 55
- ISO 5211

Certifications

Company Certifications

- ISO9001 Quality Management System
- ISO14001 Environmental Management System
- API Monogram License 6D-0197, 600-0016

Product Certificates

- Fire Safe API 607, ISO 10497, API 6FA
- PED 2014/68/EU - CE marking
- ATEX 2014/34/EU– (II2GD)
- Russian Federation Certificate TRCU 10, TRCU 12, TRCU 32
- Food processing and pharmaceutical industry FDA, USP CLASS VI COMPLIANCE (CE 1935/2004)
- Safety Integrity Level (SIL) LEVEL 3 IEC 61508
- CRN (Canadian Registration Number)
- AGA 8328 G – AS4617 2004 amd 1 - AGA marking (Australian Gas Association)
- Fugitive Emissions ISO 15848, TA LUFT (VDI 2440)

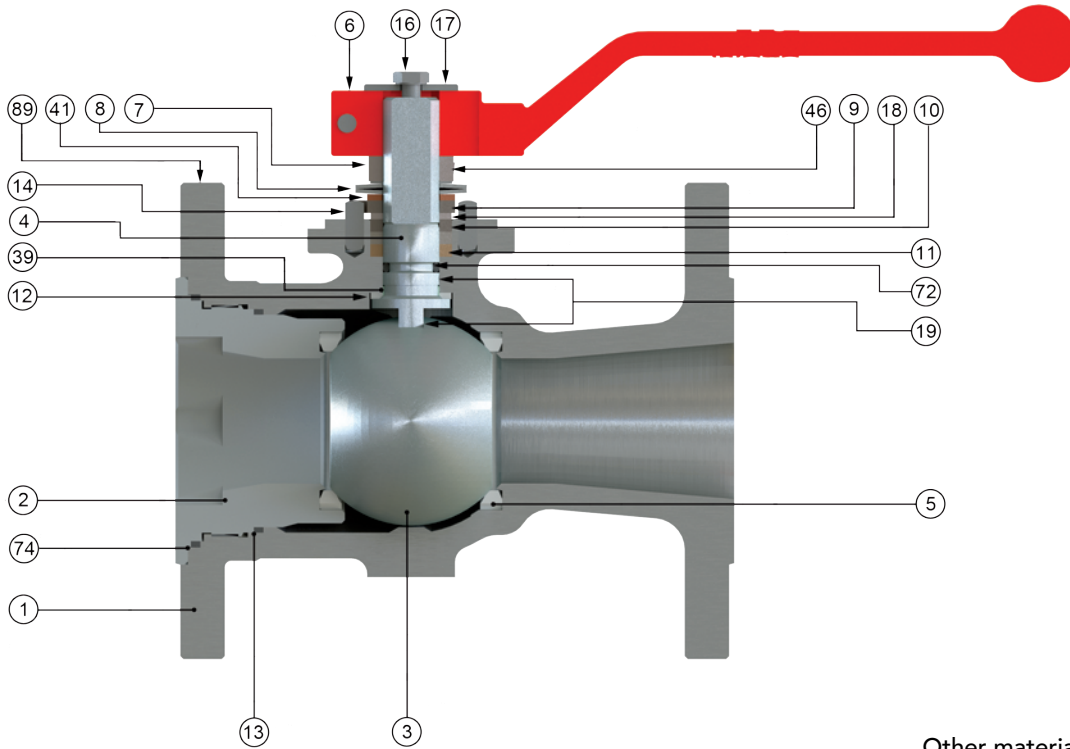

Other materials upon request

Item	Description	Material		
		A.I.T	I.I.T	L.I.T.
1 / 2	Body / Body Insert	A 216 Gr. WCB (C ≤ 0,25%)	ASTM A 351 Gr. CF8M	ASTM A 352 LCC
3	Ball	ASTM A 351 Gr. CF8M (DN 15 to 50 A182 Gr. F316)		
4	Stem	ASTM A 479 Tp.316		
5	Seat ring	PTFE		
6	Wrench	A 216 Gr. WCB		
7	Gland nut	Zinc plated carbon steel	AISI 303	
8	Disk spring	Carbon St.	A 666 Tp.301	
9	Stop plate	Carbon St.	AISI 304	
10	Gland	AISI 303	AISI 316	
11	Gland packing	Graphite		
12	Stem thrust seal	25% G.F. PTFE		
13	Body connector seal	PTFE		
14	Stop pin	Carbon St.	Stainless St.	
16	Bolt	DIN 933 A4-70		
17	Washer	AISI 304		
18	Thrust washer	25% G.F. PTFE		
19	Antistatic device	Stainless St.		
39	Stem bushing (DN 40 to DN 300)	25% G.F. PTFE		
41	Spacer (DN 40 to 250)	Carbon St.	AISI 304	
46	Washer	AISI 304		
72	O-Ring	FKM		
74	Insert Seal	Graphite		
89	Identification plate	Stainless St.		

ANSI Ball Valves
F l o a t i n g

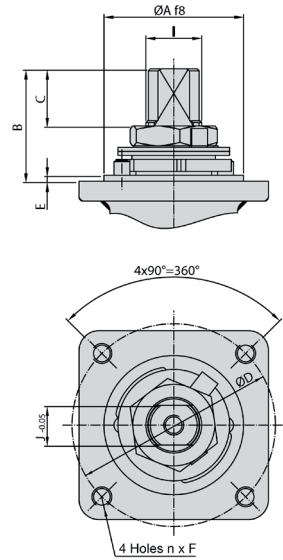
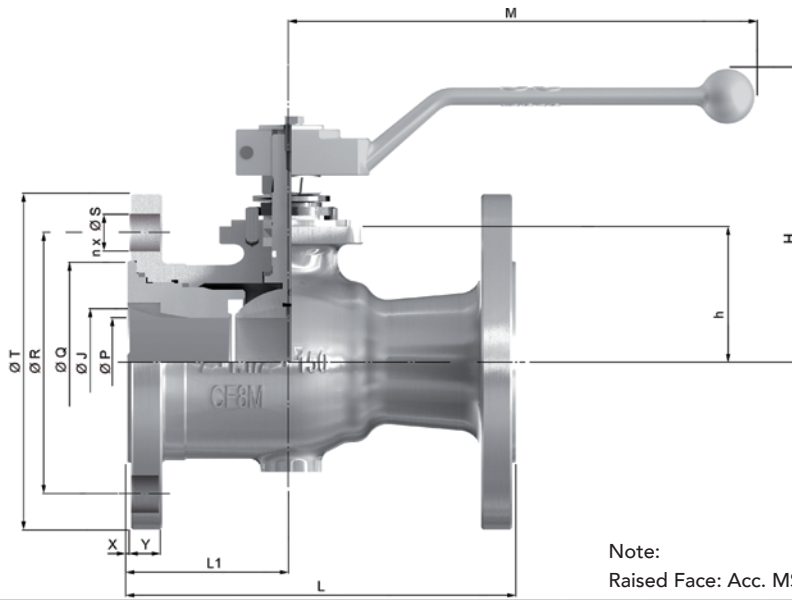

Note:
Raised Face: Acc. MSS SP-6

* Weight in Kg * Dimensions in mm

Series 715 (Class 150)

DN	ØJ	ØP	L	L1	ØQ	ØR	n x ØS	ØT	X	Y	h	H	M	WEIGHT	Kv
15 (½")	15	9,5	108	54	34,9	60,3	4x15,9	90	2	8	21,5	81	164	1,6	7
20 (¾")	20	15	117	60	42,9	69,9	4x15,9	100	2	8,9	26	99	164	2,1	10
25 (1")	25	20	127	65	50,8	79,4	4x15,9	110	2	9,6	29	102	164	2,7	26
40 (1½")	40	32	165	72	73	98,4	4x15,9	125	2	12,7	51	117	210	5,1	107
50 (2")	50	40	178	75	92,1	120,7	4x19,1	150	2	14,3	61,5	133	213	7,9	140
80 (3")	80	58	203	88	127	152,4	4x19,1	190	2	17,5	76	148	348	14,3	300
100 (4")	102	80	229	104	157,2	190,5	8x19,1	230	2	22,3	92,5	189	445	25,9	600
150 (6")	152	111	267	125	215,9	241,3	8x22,2	280	2	23,9	129	228	495	43,8	1000
200 (8")	200	144	292	135	269,9	298,5	8x22,2	345	2	27	158	267	698	77	2000
250 (10")	254	187	330	165,5	323,8	362	12x25,4	405	2	28,6	191	---	---	114	4100
300 (12")	305	228	356	178	381	431,8	12x25,4	485	2	30,2	255	---	---	230	6900

(1) Body and Body connector joint is not threaded, is with screws (not shown in the drawing).

Series 730 (Class 300)

DN	ØJ	ØP	L	L1	ØQ	ØR	n x ØS	ØT	X	Y	h	H	M	WEIGHT	Kv
15 (½")	15	9,5	140	54	34,9	66,7	4x15,9	95	2	12,7	21,5	81	164	1,6	7
20 (¾")	20	15	152	60	42,9	82,6	4x19,1	115	2	14,3	26	99	164	2,1	10
25 (1")	25	20	165	65	50,8	88,9	4x19,1	125	2	15,9	29	102	164	4,1	26
40 (1½")	40	32	190	72	73	114,3	4x22,2	155	2	19,1	51	117	210	8,2	107
50 (2")	50	40	216	75	92,1	127	8x19,1	165	2	20,7	61,5	134	213	10,9	140
80 (3")	80	58	282	88	127	168,3	8x22,2	210	2	27	76	148	348	21,4	300
100 (4")	102	80	305	104	157,2	200	8x22,2	255	2	30,2	92,5	189	445	28,9	600
150 (6")	152	111	403	125	215,9	269,9	12x22,2	320	2	35	129	228	495	70	1000
200 (8")	200	144	419	135	269,9	330,2	12x25,4	380	2	39,7	158	267	698	110,5	2000

Actuator Connection

DN	ISO 5211	ØA	B	C	ØD	n x F	E	I	J
15 (½")	F05	35	22	7,9	50	4x M6	1,5	M10x1,5	7
20 (¾")	F05	35	22,7	8,5	50	4x M6	3	M12x1,5	9
25 (1")	F05	35	22,7	8,5	50	4x M6	3	M12x1,5	9
40 (1½")	F05	35	34,5	14	50	4x M6	3	M16x1,5	12
50 (2")	F07	55	42	18,8	70	4x M8	3	M18x1,5	13
80 (3")	F07	55	44	18,6	70	4x M8	3	M22x1,5	16
100 (4")	F10	70	44,5	18,6	102	4x M10	3	M25x1,5	18
150 (6")	F12	85	56,5	27,8	125	4x M12	3	M28x1,5	20
200 (8")	F12	85	56	24,8	125	4x M12	3	M35x2	25
250 (10")	F12	85	68,4	37,5	125	4x M12	3	M40x2	29
300 (12")	F14	100	97	56	140	4x M16	4	Ø 50	14

Differential Pressure 150 Lbs

DN	BTO	RTO	ETO	BTC	RTC	ETC	MAST
15	8	4	5	6	4	6	13
20	9	5	5	7	5	7	26
25	11	6	7	8	6	9	26
40	17	9	10	13	9	14	69
50	28	14	17	21	14	22	85
80	58	29	35	44	29	46	176
100	85	43	51	64	43	68	246
150	228	114	137	171	114	182	305
200	352	176	211	264	176	282	607
250	610	305	366	458	305	488	974
300	980	490	588	735	490	784	2800

Differential Pressure 300 Lbs

DN	BTO	RTO	ETO	BTC	RTC	ETC	MAST
15	10	5	6	8	5	8	13
20	12	6	7	9	6	10	26
25	16	8	10	12	8	13	26
40	26	13	16	20	13	21	69
50	35	18	21	26	18	28	85
80	70	35	42	53	35	56	176
100	90	45	54	68	45	72	246
150	280	140	168	210	140	224	305
200	515	258	309	386	258	412	607
-	-	-	-	-	-	-	-
-	-	-	-	-	-	-	-

Pressure – Temperature Charts

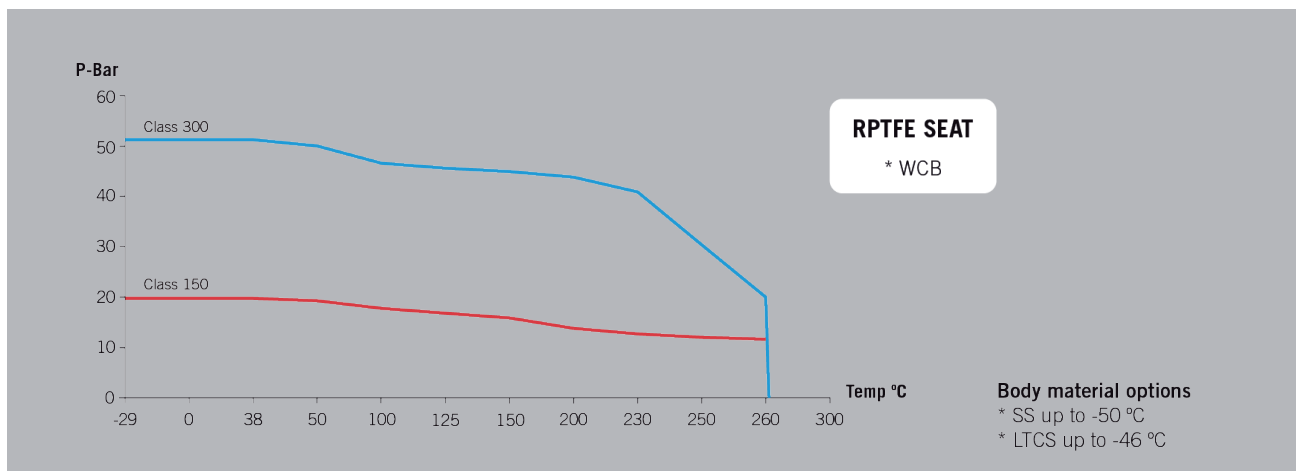
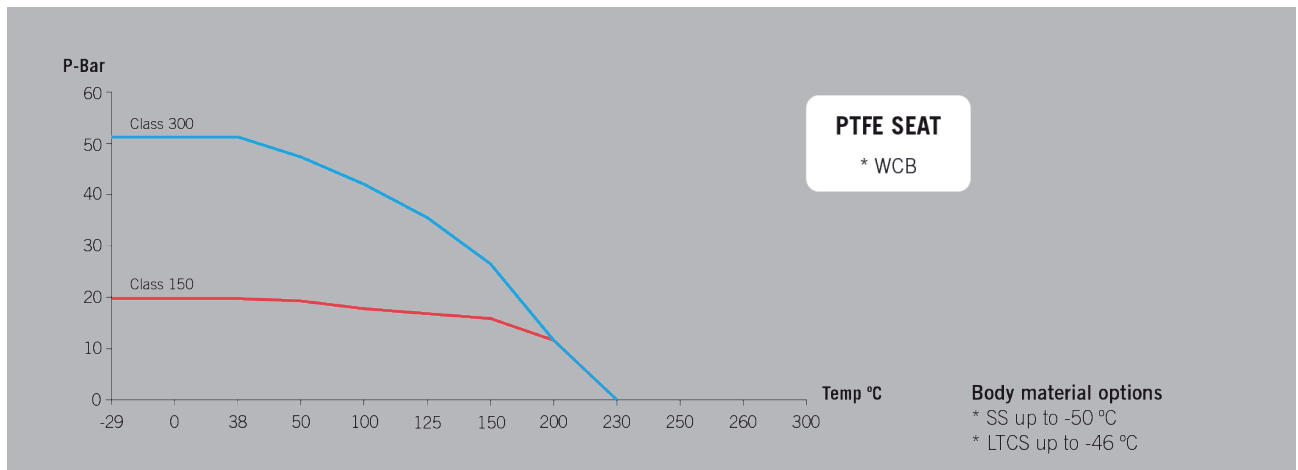



Simple Stem Extension



Stem Extension



Cavity Relief Seat

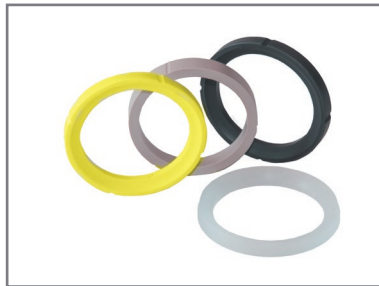

Other Seat materials



Stainless Steel Lever

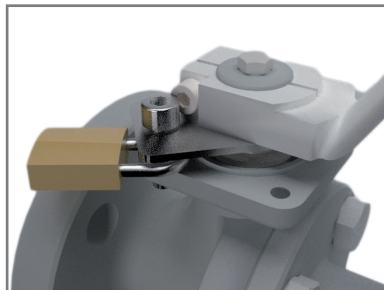

Locking Device

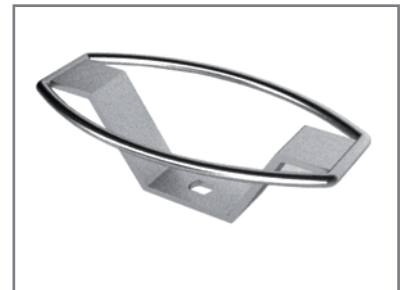

Oval Handwheel
Available from 1/2" to 2"



**Manual and Declutchable
Gears**



**Pneumatic or Hydraulic
Scotch Yoke Actuators**



**Valve Automation option
available on Request**