



FUGITIVE
EMISSIONS
EN-ISO 15848-1
TALUFT / VDI 2440

- Valve design: Full Bore API 6D
- Body design: ASME VIII Div.1
- Shell thickness: ASME B16.34
- Flanges: ASME B16.5 Raised Face
- Face to face dimensions: ASME B16.10 Long Pattern
- Marking: API 6D / CE - PED / MSS SP25
- Pressure testing: API 598 - API 6D
- Shell finishing quality: MSS SP 55
- ISO 5211

Certifications

Company Certifications

- ISO9001 Quality Management System
- ISO14001 Environmental Management System
- API Monogram License 6D-0197, 600-0016

Product Certificates

- Fire Safe API 607, ISO 10497, API 6FA
- Fugitive Emissions ISO 15848 TA LUFT (VDI 2440)
- PED 2014/68/EU - CE marking
- ATEX 2014/34/EU- (II2GD)
- Russian Federation Certificate TRCU 10, TRCU 12, TRCU 32
- Food processing and pharmaceutical industry FDA, USP CLASS VI COMPLIANCE (CE 1935/2004)
- Safety Integrity Level (SIL) LEVEL 3 IEC 61508
- CRN (Canadian Registration Number)
- Tanks for the transport of dangerous goods-Tank equipment for the transport of liquid chemicals and liquefied gases - Product discharge and air inlet valves EN 14432
- AGA 8328 G – AS4617 2004 amd 1 - AGA marking (Australian Gas Association)
- CSA 3.16 – 2015 CSA marking (Canadian Standard Association)

ANSI Ball Valves
Floating

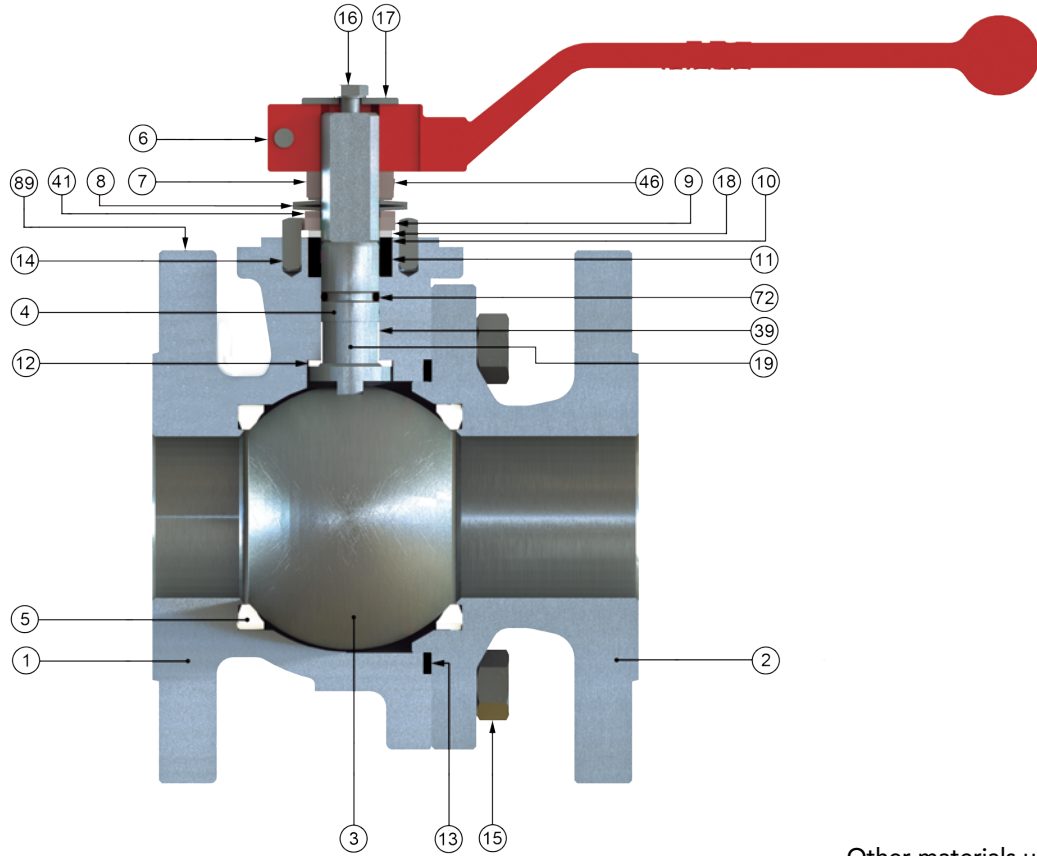

Other materials upon request

Item	Description	Material		
		A.I.T	I.I.T	L.I.T.
1 / 2	Body / Body Connector	A 216 Gr. WCB (C ≤ 0,25%)	ASTM A 351 Gr. CF8M	ASTM A 352 LCC
3	Ball	ASTM A 351 Gr. CF8M (DN 15 to 50 A182 Gr. F316)		
4	Stem	ASTM A 479 Tp.316		
5	Seat ring	PTFE		
6	Wrench	A 216 Gr. WCB		
7	Gland nut	Zinc plated carbon steel	AISI 303	
8	Disk spring	Carbon St.	A 666 Tp.301	
9	Stop plate	Carbon St.	AISI 304	
10	Gland	AISI 303	AISI 316	
11	Gland packing	Graphite		
12	Stem thrust seal	25% G.F. PTFE		
13	Body connector seal	SPW AISI 316L + PTFE + Graphite		
14	Stop pin	Carbon St.	Stainless St.	
15	Bolt	A 193 Gr. B7M Zinc Bichromated	A 193 Gr. B8M	A 320 Gr. L7M Zinc Bichromated
16	Bolt	DIN 933 A4-70		
17	Washer	AISI 304		
18	Thrust washer	25% G.F. PTFE		
19	Antistatic device	Stainless St.		
39	Stem bushing (DN 25 to DN 200)	25% G.F. PTFE		
41	Spacer (DN 40 to 200)	Carbon St.	AISI 304	
46	Washer	AISI 304		
72	O-Ring	FKM		
89	Identification Plate	Stainless St.		

ANSI Ball Valves
F l o a t i n g

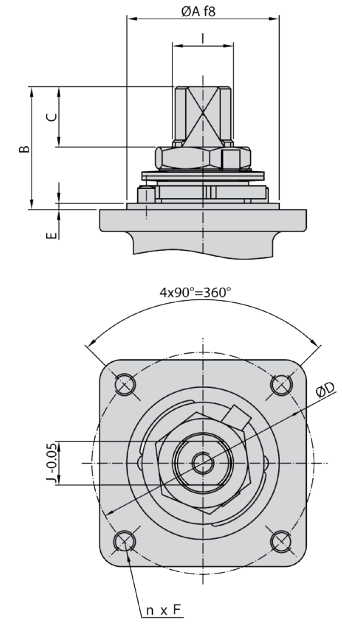
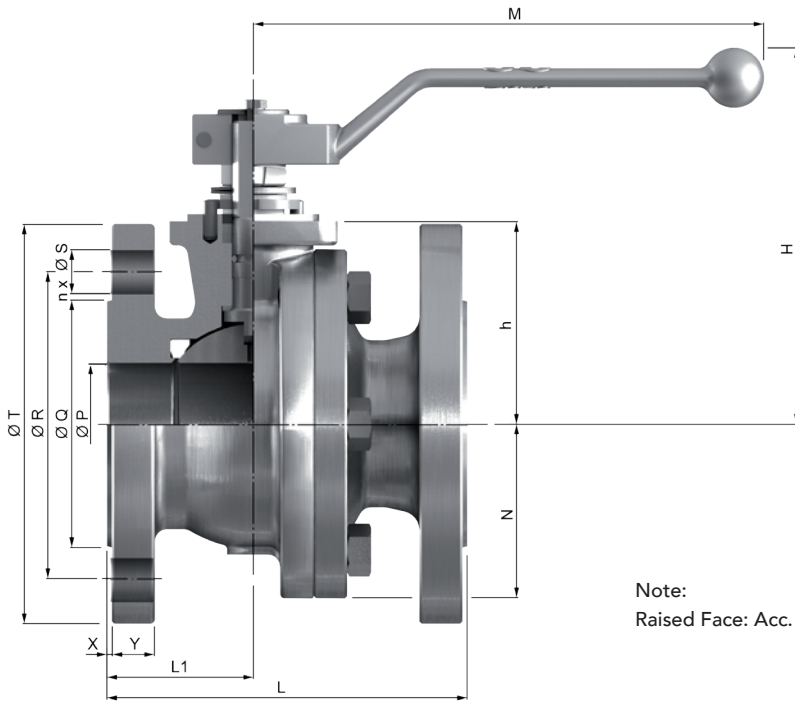

Note:
Raised Face: Acc. MSS SP-6

Series 515 (Class 150)

DN	ØP	L	L1	ØQ	ØR	n x ØS	ØT	X	Y	h	H	M	N	WEIGHT	Kv
15 (1/2")	15	108	47	34,9	60,3	4x15,9	90	2	8	46	111	164	---	2	20
20 (3/4")	20	117	50	42,9	69,9	4x15,9	100	2	8,9	53	118	164	---	3	40
25 (1")	25	127	52	50,8	79,4	4x15,9	110	2	9,6	58	130	164	---	3,5	75
40 (1 1/2")	40	165	65	73	98,4	4x15,9	125	2	12,7	76	148	213	---	8	170
50 (2")	50	178	61	92,1	120,7	4x19,1	150	2	14,3	83,5	155	213	---	11	270
65 (2 1/2")	65	190	75	104,8	139,7	4x19,1	180	2	15,9	97	169	348	---	16	550
80 (3")	80	203	78,5	127	152,4	4x19,1	190	2	17,5	111	207	445	---	23	1000
100 (4")	100	229	90	157,2	190,5	8x19,1	230	2	22,3	133	232	495	120	38	1650
150 (6")	151	394	174	215,9	241,3	8x22,2	280	2	23,9	183	298	698	168	88	4200
200 (8")	203	457	200	269,9	298,5	8x22,2	345	2	27	233	353	868	208	155	9000

Series 530 (Class 300)

DN	ØP	L	L1	ØQ	ØR	n x ØS	ØT	X	Y	h	H	M	N	WEIGHT	Kv
15 (1/2")	15	140	60	34,9	66,7	4x15,9	95	2	12,7	46	111	164	---	3	20
20 (3/4")	20	152	65	42,9	82,6	4x19,1	115	2	14,3	53	118	164	---	4	40
25 (1")	25	165	70	50,8	88,9	4x19,1	125	2	15,9	58	130	164	---	5	75
40 (1 1/2")	40	190	80	73	114,3	4x22,2	155	2	19,1	76	148	213	---	11	170
50 (2")	50	216	83	92,1	127	8x19,1	165	2	20,7	83,5	155	213	---	14	270
80 (3")	80	282	118	127	168,3	8x22,2	210	2	27	111	207	445	---	32	1000
100 (4")	100	305	133	157,2	200	8x22,2	255	2	30,2	133	232	495	---	52	1650
150 (6")	151	403	160	215,9	269,9	12x22,2	320	2	35	183	298	698	168	94	4200

Actuator Connection

DN	ISO 5211	ØA	B	C	ØD	n x F	E	I	J
15 (1/2")	F05	35	11,2	5	50	4x M6	1,5	M12x1,5	9
20 (3/4")	F05	35	14,7	8,5	50	4x M6	1,5	M12x1,5	9
25 (1")	F05	35	22,7	9,5	50	4x M6	1,5	M12x1,5	9
40 (1 1/2")	F07	55	41,5	18,3	70	4x M8	3	M18x1,5	13
50 (2")	F07	55	41,5	18,3	70	4x M8	3	M18x1,5	13
65 (2 1/2")	F07	55	44	18,6	70	4x M8	3	M22x1,5	16
80 (3")	F10	70	44,5	18,6	102	4x M10	3	M25x1,5	18
100 (4")	F10	70	56,5	27,8	102	4x M10	3	M28x1,5	20
150 (6")	F12	85	68	37,1	125	4x M12	3	M40x2	29
200 (8")	F14	100	72	36,5	140	4x M16	4	M45x2	32

Differential Pressure 150 Lbs

DN	BTO	RTO	ETO	BTC	RTC	ETC	MAST
15	9	5	5	7	5	7	26
20	13	7	8	10	7	10	26
25	17	9	10	13	9	14	26
40	30	15	18	23	15	24	85
50	43	22	26	32	22	34	85
65	66	33	40	50	33	53	176
80	102	51	61	77	51	82	246
100	150	75	90	113	75	120	305
150	326	163	196	245	163	261	974
200	729	365	437	547	365	583	1387

Differential Pressure 300 Lbs

DN	BTO	RTO	ETO	BTC	RTC	ETC	MAST
15	12	6	7	9	6	10	26
20	16	8	10	12	8	13	26
25	20	10	12	15	10	16	26
40	37	19	22	28	19	30	85
50	55	28	33	41	28	44	85
-	-	-	-	-	-	-	-
80	128	64	77	96	64	102	246
100	238	119	143	179	119	190	305
150	492	246	295	369	246	394	974
-	-	-	-	-	-	-	-

Pressure – Temperature Charts

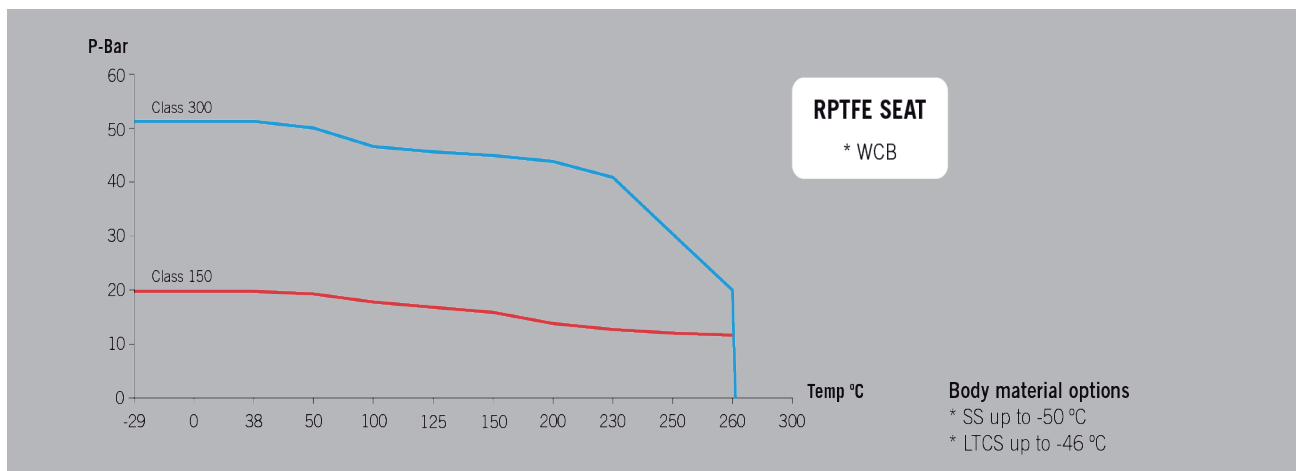
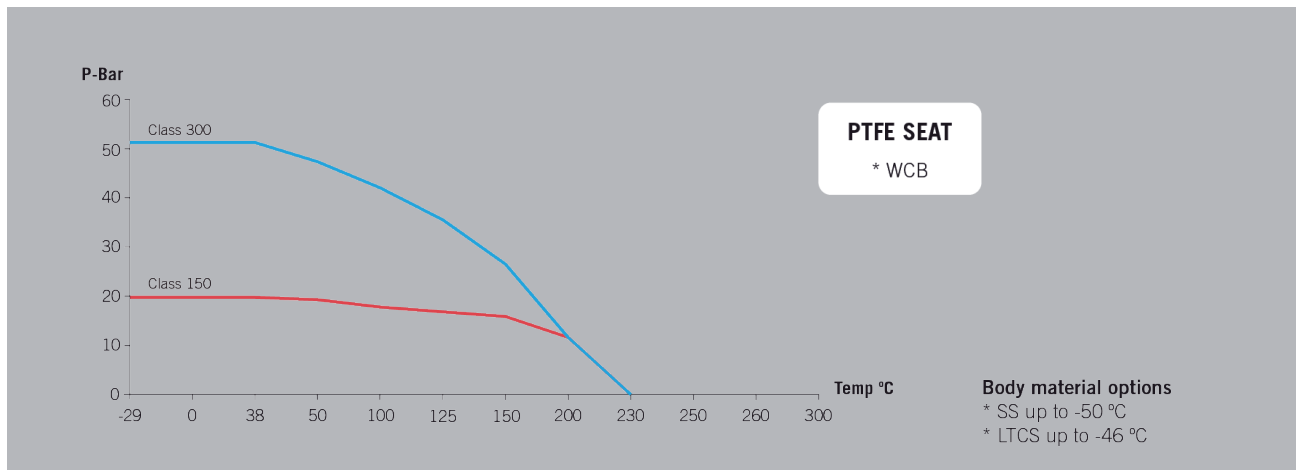



Simple Stem Extension



Stem Extension

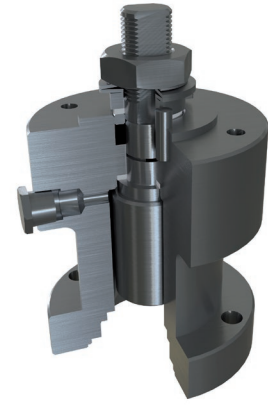

Double Packing Stem Extension



Cavity Relief Seat

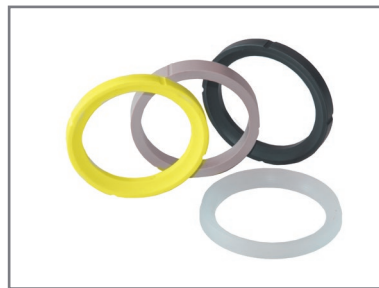

Other Seat materials



Cavity Filler Seat



Stainless Steel Lever

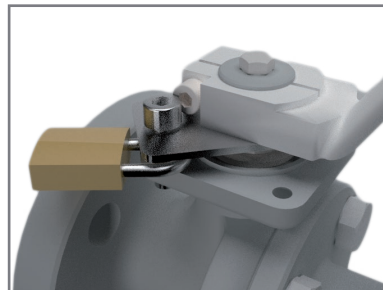

Locking Device



Oval Handwheel
Available from 1/2" to 2"



**Manual and Declutchable
Gears**

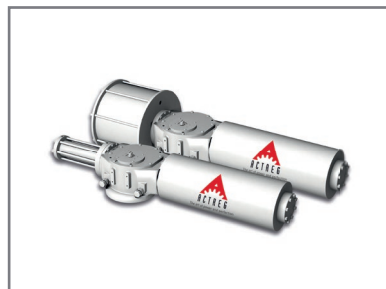

**Pneumatic or Hydraulic
Scotch Yoke Actuators**



**Valve Automation option
available on Request**