

3-Way Ball Valve 1000 WOG (PN63)

L9.622 mit L-bore

T9.622 mit T-bore

DN 1/4" - 3" (DN 8 - 80) of Stainless Steel
reduced bore, with threaded ends ISO 228/1



DESIGN FEATURES

- Built-in ISO 5211 Direct Mounting Pad Easy Automation
- Anti-static Devices for Ball-Stem-Body
- Blow-out Proof Stem
- Positive Position location at 90° Increments
- Locking in Every 90° Increments
- TA-Luft Design Approved
- NACE MR-0175 (Optional)
- Casting Approved by TÜV AD 2000-Merkblatt W0



APPLICABLE STANDARDS

- Design Standard : MSS SP-110
- Wall Thickness : EN12516-3
- Pipe Thread : ASME B1.20.1, BS21, EN 10226
DIN 2999/259, ISO 228/1
JIS B0203 ISO 7/1
- Inspection & Testing : MSS SP-110

WEIGHT

DN	NPS	KV-L50		KV-L51	
		(kg)	(lb)	(kg)	(lb)
8	1/4	0.86	1.89	0.84	1.85
10	3/8	0.83	1.83	0.82	1.81
15	1/2	0.77	1.69	0.76	1.67
20	3/4	1.05	2.31	1.03	2.27
25	1	1.88	4.14	1.8	3.96
32	1 1/4	3.07	6.76	3.01	6.64
40	1 1/2	4.26	9.37	4.12	9.06
50	2	7.10	15.65	7.02	15.44

3-Way Ball Valve 1000 WOG (PN63)

L9.622 mit L-bore

T9.622 mit T-bore

DN 1/4" - 3" (DN 8 - 80) of Stainless Steel

reduced bore, with threaded ends ISO 228/1



TORQUE VALUES

Close to Open Torque at Various Differential Pressure (ΔP), Standard Seats (TFM1600 & PTFE)

unit : in-lb / N-m

Size/ ΔP		75 psig		150 psig		300 psig		700 psig		1000 psig	
		5 bar		10 bar		20 bar		50bar		63bar	
NPS	DN	N-m	In-lb	N-m	In-lb	N-m	In-lb	N-m	In-lb	N-m	In-lb
1/4	8	9	80	9	80	9	80	9	80	9	80
3/8	10	9	80	9	80	9	80	9	80	9	80
1/2	15	9	80	9	80	9	80	9	80	9	80
3/4	20	9	80	9	80	10	88	10	88	10	88
1	25	14	124	14	124	15	133	15	133	15	133
1 1/4	32	18	159	18	159	18	159	20	177	22	195
1 1/2	40	25	221	26	230	26	230	28	248	30	265
2	50	35	310	38	336	42	372	46	407	50	442

Remark :

- 1.The torque figures at 5 bar pressure are maximum values to be tested after the valves are placed for 24 hours.
- 2.For actuator sizing, a safety factor of minimum 30% is recommended.

TECHNICAL INFORMATION

PRESSURE - TEMPERATURE DATA

The pressure-temperature data of ball valves are determined not only by valve shell materials but also by sealing materials used for ball seats, gland packings and flange gaskets.

Reduced Bore: NPS 1/4 to NPS 1 1/4
DN8 to DN32

Reduced Bore: NPS 1 1/2 to NPS 2
DN40 to DN50

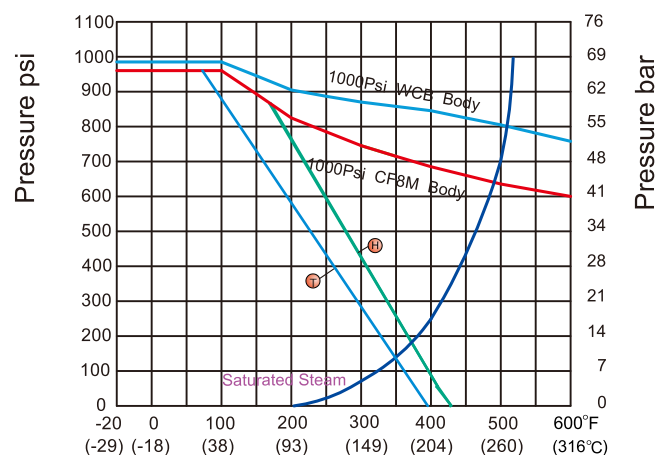
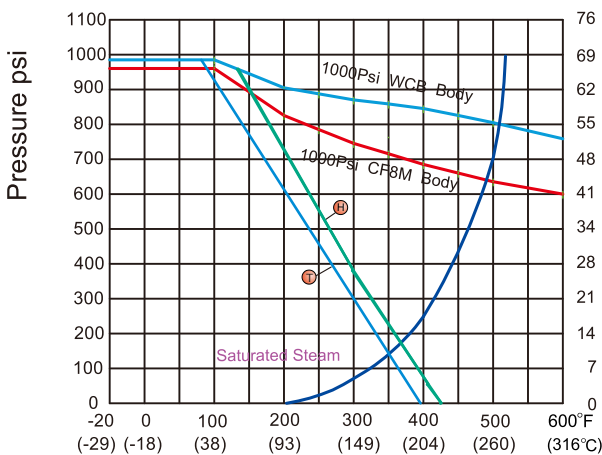

Temperature °F (°C)

Temperature °F (°C)

Seat Materials : (●) PTFE (⊕) TFM1600

Body Ratings: Shown above are for ASTM A351 Gr.CF8M and A216 Gr.WCB

For ratings of other valve shell materials, please refer to the last edition of ASME B16.34.

3-Way Ball Valve 1000 WOG (PN63)

L9.622 mit L-bore

T9.622 mit T-bore

DN 1/4" - 3" (DN 8 - 80) of Stainless Steel

reduced bore, with threaded ends ISO 228/1

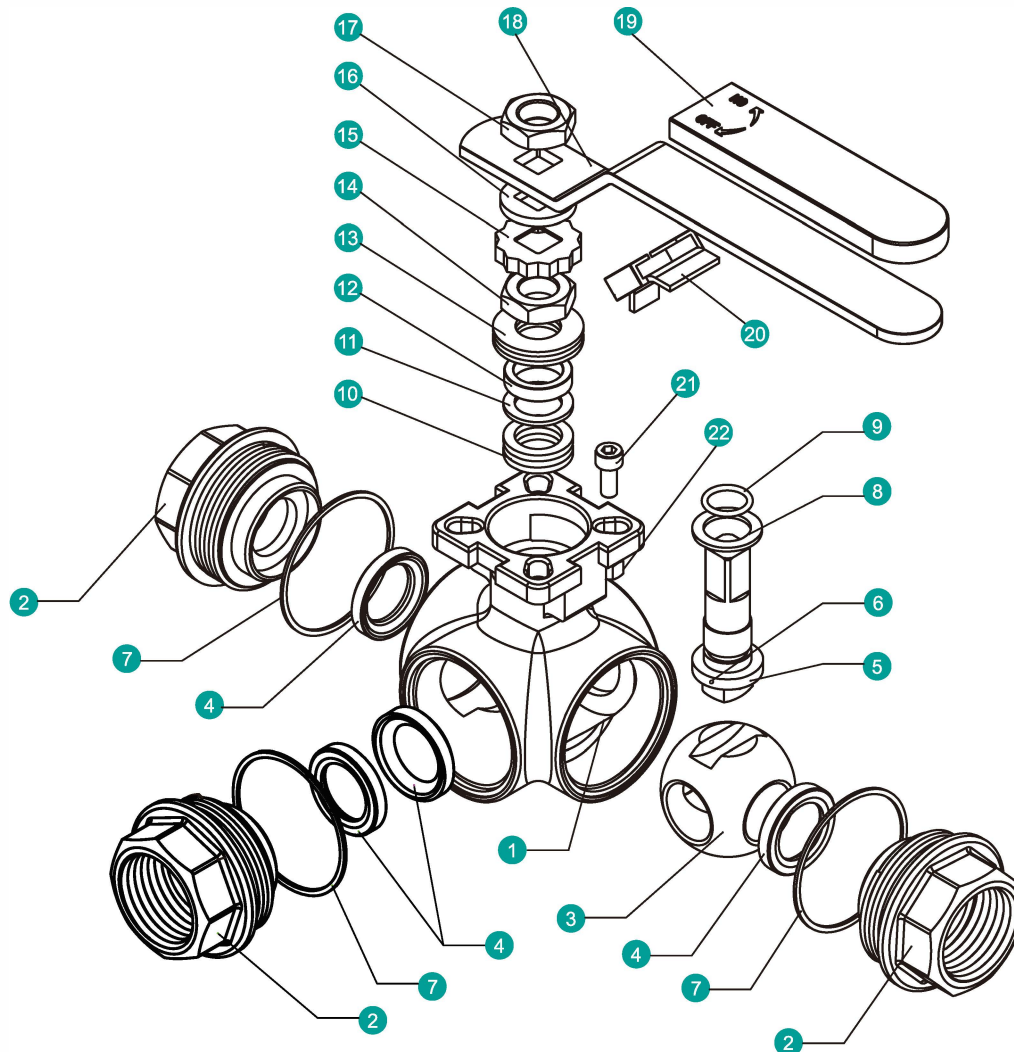

MATERIAL OF CONSTRUCTION

NO.	PART NAME	MATERIALS		
1	Body	CF8M(1.4408)	CF8(1.4308)	WCB(1.0619)
2	End Cap (Thread)	CF8M(1.4408)	CF8(1.4308)	WCB(1.0619)
3	Ball	316	304	
4	Ball Seat	TFM1600 /PTFE		
5	Washer	316	304	
6	Stem (Anti-Static)	316	304	
7	Body Gasket	PTFE		
8	Thrust washer	PTFE/ TFM1600		
9	O-Ring	FKM		
10	Packing	PTFE		
11	Bushing	50%SS+50%PTFE		
12	Gland	316		
13	Belleville Washer	301		
14	Stem Nut	A194-8		
15	Stop-lock-Cap	304		
16	Handle Gland	304		
17	Handle Nut	A194-8		
18	Handle	304		
19	Handle Sleeve	VINYL PLASTIC		
20	Lock Device	304		
21	Stop Bolt	A2-70		
22	Stop Nut	A2-70		

3-Way Ball Valve 1000 WOG (PN63)

L9.622 mit L-bore

T9.622 mit T-bore

DN 1/4" - 3" (DN 8 - 80) of Stainless Steel

reduced bore, with threaded ends ISO 228/1

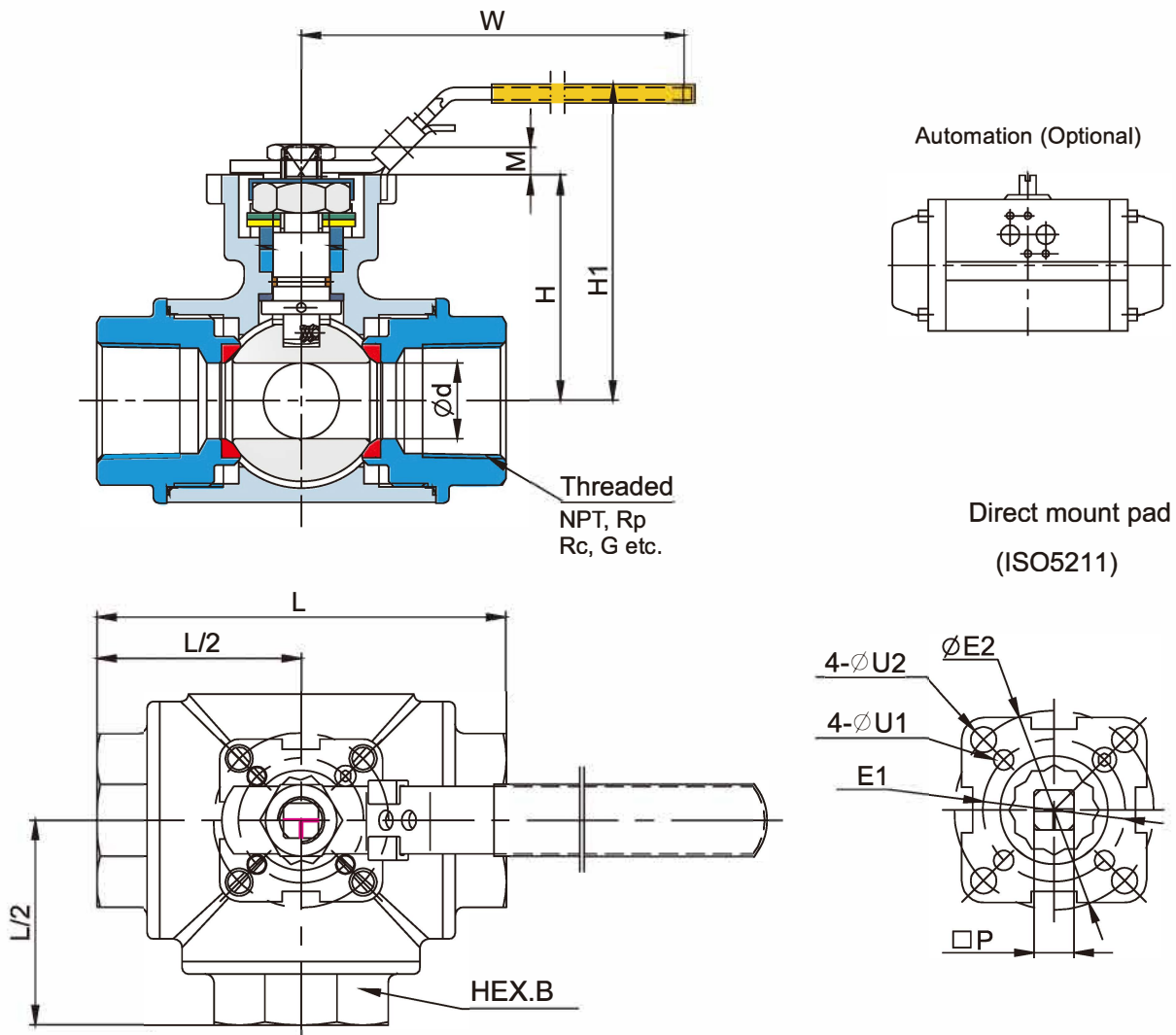

DIMENSION TABLE

Unit : mm

DN	NPS	d	L	H	H1	W	P	M	E1	E2	U1	U2	HEX.B	ISO 5211
8	1/4	11	79	43.0	73	147	9	9	36	42	6	6	27	F03~F04
10	3/8	11	79	43.0	73	147	9	9	36	42	6	6	27	F03~F04
15	1/2	11	79	43.0	73	147	9	9	36	42	6	6	27	F03~F04
20	3/4	15	88	49.0	79	147	9	9	36	50	6	7	34	F03~F05
25	1	20	108	59.5	91	177	11	11	42	50	6	7	41	F04~F05
32	1 1/4	25	124	63.0	93	177	11	11	42	70	6	9	50	F04~F07
40	1 1/2	32	135	73.5	105	215	14	14	50	70	7	9	56	F05~F07
50	2	40	164	82.8	115	215	14	14	50	70	7	9	70	F05~F07

Unit : inch

DN	NPS	d	L	H	H1	W	P	M	E1	E2	U1	U2	HEX.B	ISO 5211
8	1/4	0.43	3.11	1.69	2.87	5.79	0.354	0.35	1.42	1.65	0.24	0.24	1.06	F03~F04
10	3/8	0.43	3.11	1.69	2.87	5.79	0.354	0.35	1.42	1.65	0.24	0.24	1.06	F03~F04
15	1/2	0.43	3.11	1.69	2.87	5.79	0.354	0.35	1.42	1.65	0.24	0.24	1.06	F03~F04
20	3/4	0.59	3.46	1.93	3.11	5.79	0.354	0.35	1.42	1.97	0.24	0.28	1.34	F03~F05
25	1	0.79	4.25	2.34	3.54	6.97	0.433	0.43	1.65	1.97	0.24	0.28	1.61	F04~F05
32	1 1/4	0.98	4.88	2.48	3.66	6.97	0.433	0.43	1.65	2.76	0.24	0.35	1.97	F04~F07
40	1 1/2	1.26	5.31	2.89	4.13	8.46	0.551	0.55	1.97	2.76	0.28	0.35	2.20	F05~F07
50	2	1.57	6.46	3.26	4.53	8.46	0.551	0.55	1.97	2.76	0.28	0.35	2.76	F05~F07

3-Way Ball Valve 1000 WOG (PN63)

L9.622 mit L-bore

T9.622 mit T-bore

DN 1/4" - 3" (DN 8 - 80) of Stainless Steel

reduced bore, with threaded ends ISO 228/1



FLOW PATTERNS FOR 3 WAY VALVE

T-PORT 90° TURN

POSITON 1 POSITON 2

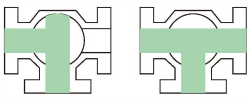

FLOW PLAN A

POSITON 1 POSITON 2

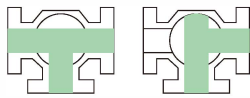

FLOW PLAN B

POSITON 1 POSITON 2

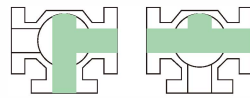

FLOW PLAN C

POSITON 1 POSITON 2

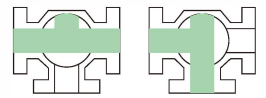

FLOW PLAN D

T-PORT 180° TURN

POSITON 1 POSITON 2 POSITON 3 FLOW PLAN E

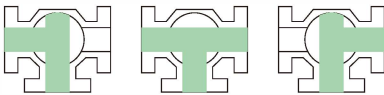

FLOW PLAN H POSITON 1 POSITON 2 POSITON 3

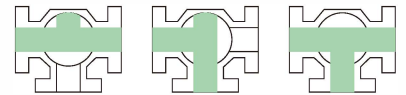

POSITON 1 POSITON 2 POSITON 3 FLOW PLAN F

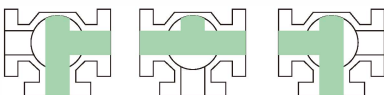

FLOW PLAN G POSITON 1 POSITON 2 POSITON 3

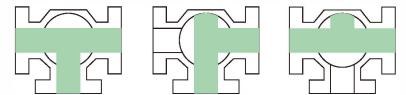

POSITON 1 POSITON 2 L-PORT 90° TURN

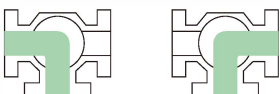

FLOW PLAN J

L-PORT 180° TURN

POSITON 1 POSITON 2 POSITON 3



FLOW PLAN K