



**FIG. R150RF**  
**FIG. R300RF**  
**CHECK VALVE**

BS5352, MSS SP 118 & ASME B16.34  
Connections according to:  
ASME B16.5



**Forged Check Valves Class 150/300**  
**Fig. R150RF & R300RF**  
*Parts and Materials*

**Parts and materials**

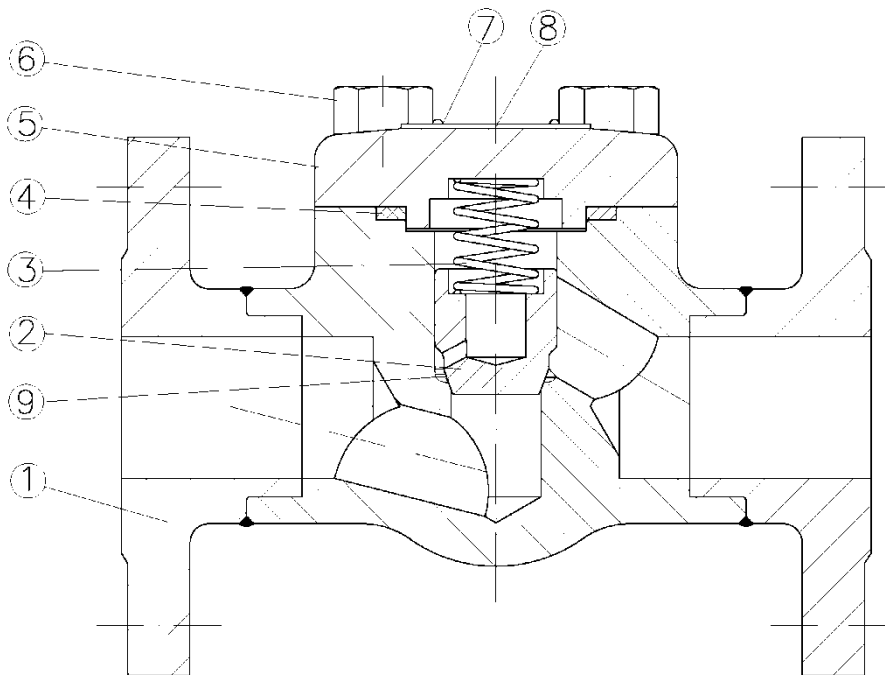

Item	Description	Material	
		Carbon Steel	Stainless Steel
1	Body	A 105	A 182 F316L
2	Piston disc	A 276 420	A 182 F316L
3	Spring	17-4 PH	
4	Gasket	AISI 304 + Graphite	AISI 316 + Graphite
5	Bonnet	A 105	A 182 F316L
6	Bolt	A 193 B7	A 193 B8M
7	Ribet	A 182 F304	A 182 F316
8	Nameplate	Aluminium	
9	Seat	A 105 + STL	A 182 F316L + STL

# Forged Check Valves Class 150/300

## Fig. R150RF & R300RF

### Dimensions

#### Dimensions

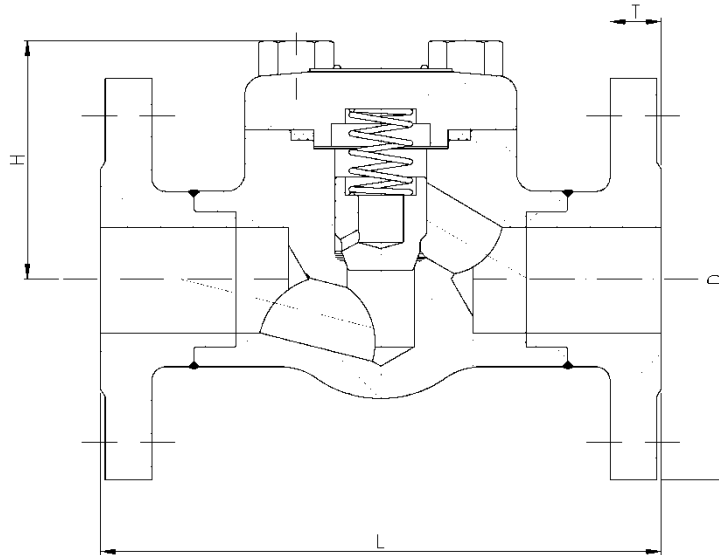

#### Series R150RF (Class 150)

SIZE	L	D	T	H	WEIGHT
1/2" (DN 15)	108	89	11,5	61	2,7
3/4" (DN 20)	117	98	13	61	3,4
1" (DN 25)	127	108	14,5	78	5
1 1/4" (DN 32)	140	118	16	84	6,1
1 1/2" (DN 40)	165	127	17,5	103	8,7
2" (DN 50)	203	152	19,5	118	14,4

(\*) Dimensions in mm and weight in kg.

#### Series R300RF (Class 300)

SIZE	L	D	T	H	WEIGHT
1/2" (DN 15)	152	95	14,5	61	4,2
3/4" (DN 20)	178	118	16	61	5,6
1" (DN 25)	203	124	17,5	78	8,3
1 1/4" (DN 32)	216	133	19,5	84	13,1
1 1/2" (DN 40)	229	156	21	103	14,2
2" (DN 50)	267	165	22,5	118	21,4

(\*) Dimensions in mm and weight in kg.

**Note:**

Dimensions not subject to International Standards can vary in  $\pm 10\%$ . ICP reserves the right to change those dimensions without notice, due to they do not affect integrity and performance of the valves.

# Forged Check Valves Class 150/300

## Fig. R150RF & R300RF

### General Characteristics, KV, P&T Rating

GENERAL CHARACTERISTICS	Forged Check Valve	Fig. R800	
<b>DESIGN STANDARDS</b>			
Valves design	BS 5352	MSS SP 118	ASME B 16.34
Connections	ANSI B 1.20.1	ANSI B 16.11	
Face to face dimensions	ASME B16,10		
<b>TESTS AND CERTIFICATES</b>			
Quality Assurance	API 598		
Pressure testing	ISO 9001		
Marking	EN 12266-1		
	EN 19		

(\*) Welded flanges

#### Kv Values in m3/h

VALVE SIZE	Kv	VALVE SIZE	Kv
½" (DN 15)	1,9	1¼" (DN 32)	11,7
¾" (DN 20)	4,2	1½" (DN 40)	17,3
1" (DN 25)	6,2	2" (DN 50)	29

#### Pressure-Temperature

**A105**

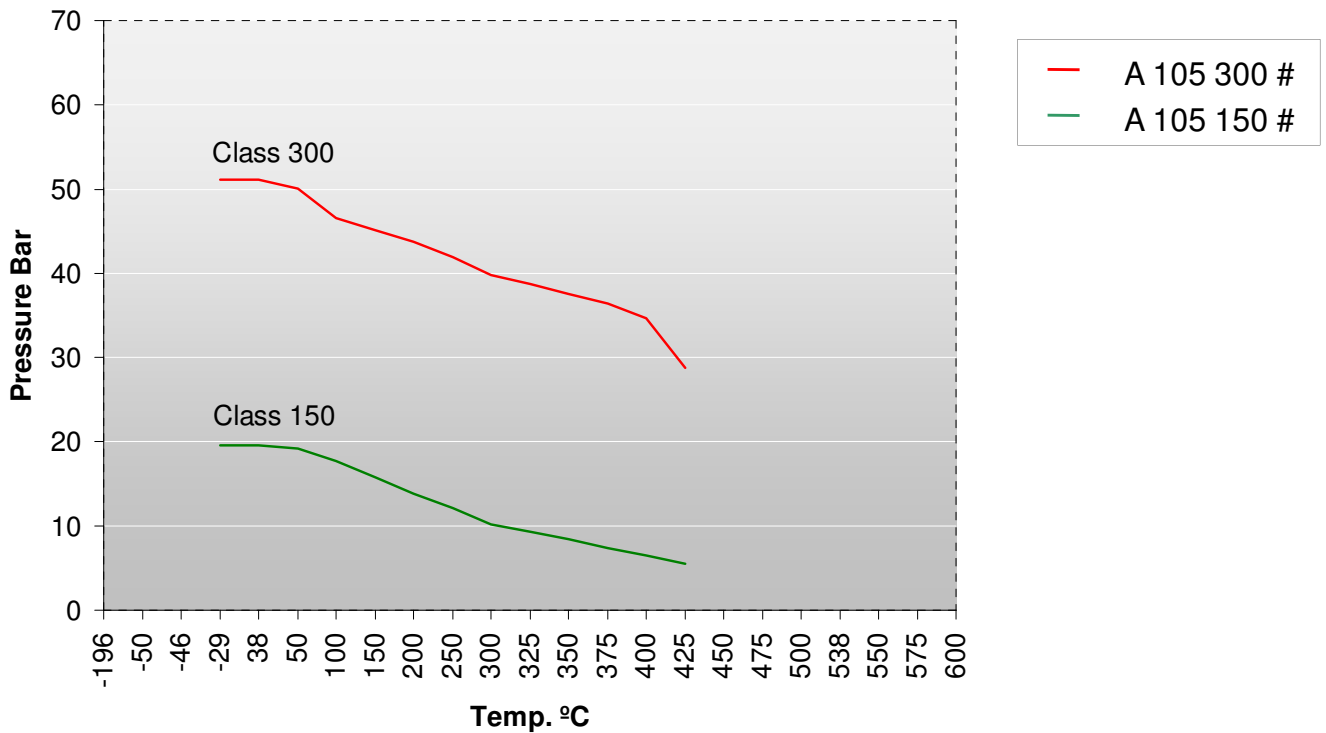

**Forged Check Valves Class 150/300**  
**Fig. R150RF & R300RF**

General Characteristics, KV, P&T Rating

**Pressure-Temperature**

**A182 F316L**

