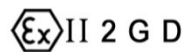



Fig. 154 / 156

Manufacturing program:



Quality & Environmental Management:



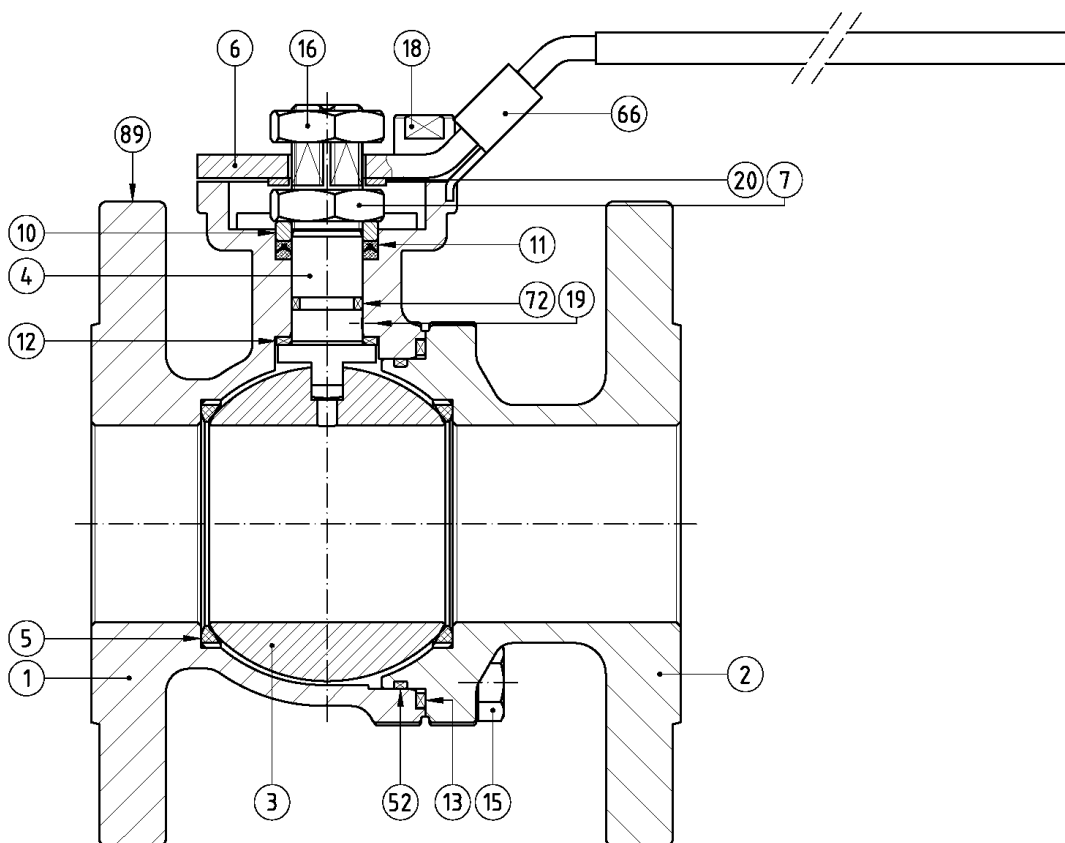

Item	Description	Material	
		AIT	IIT
1	BODY	1.0619	1.4408
2	BODY CONNECTOR	1.0619	1.4408
3	BALL	A 351 Gr. CF8M / A 479 Tp.316	
4	STEM	A 479 Tp.316	
5	SEAT RING	PTFE	
6	WRENCH	AISI 304	
7	GLAND NUT	A2	
10	GLAND RING	AISI 304	
11	GLAND PACKING	PTFE	
12	STEM THRUST SEAL	PTFE + 25% GF	
13	BODY CONNECTOR SEAL	PTFE	
15	BOLT	8.8	A2
16	WRENCH NUT	A2	
18	STOP PIN	AISI 304	
19	ANTISTATIC DEVICE	STAINLESS STEEL	
20	SPACER	AISI 304	
52	"O" RING	FKM	
66	LOCKING DEVICE	AISI 304	
72	"O" RING	FKM	
89	IDENTIFICATION PLATE	AISI 304	
	PLASTIC CAP	PLASTIC	

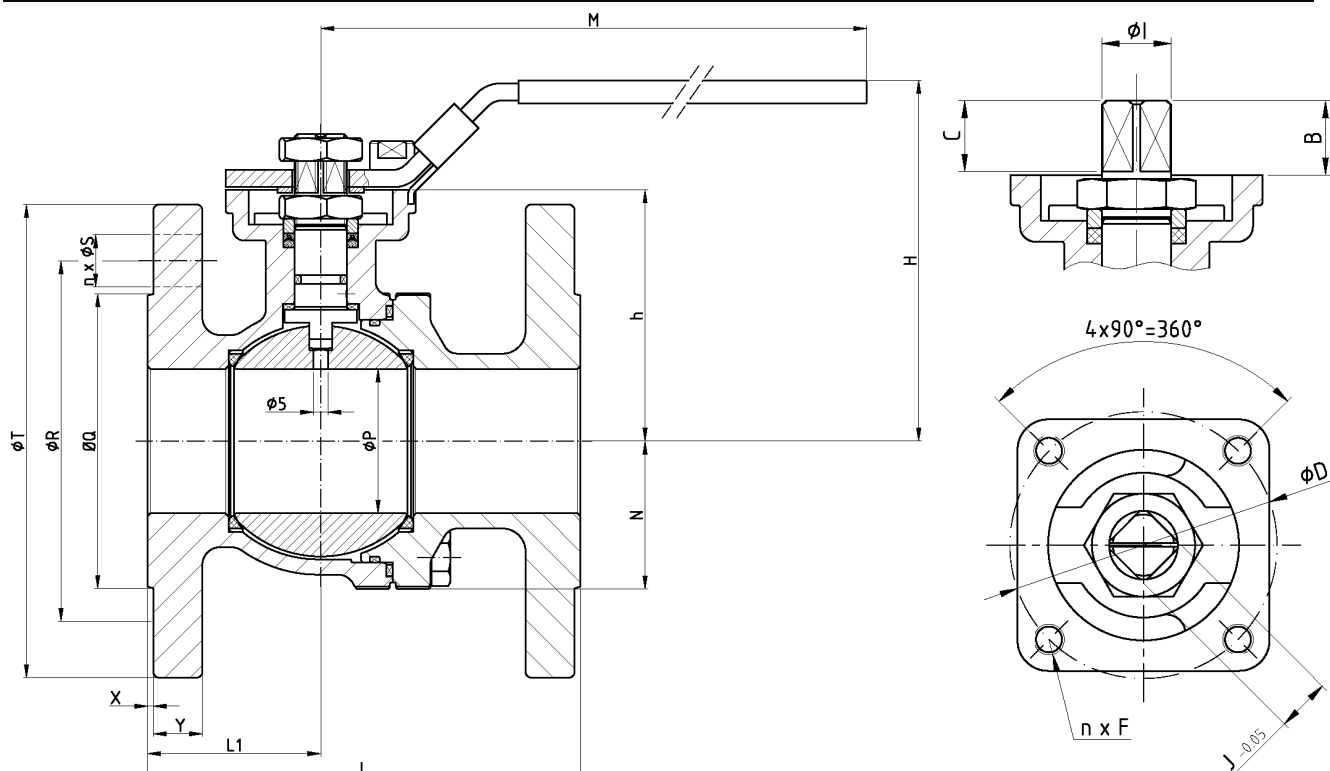

Series 154 (PN 40)

DN	ØP	L	L1	ØQ	ØR	n x ØS	ØT	X	Y	h	N	H	M	Weight
15	13	115	48	45	65	4 x 14	95	2	16	40	-	78	171	2
20	17	120	52	58	75	4 x 14	105	2	18	44,5	-	82	171	3
25	24	125	46	68	85	4 x 14	115	2	18	60	-	88	171	4
32	31	130	47	78	100	4 x 18	140	2	18	72	-	100	171	6
40	38	140	54	88	110	4 x 18	150	3	18	79,5	-	118	301	7
50	50	150	60	102	125	4 x 18	165	3	20	87	-	125	301	10

(*) Dimensions in mm

Series 156 (PN 16)

DN	ØP	L	L1	ØQ	ØR	n x ØS	ØT	X	Y	h	N	H	M	Weight
65	65	170	69	122	145	4 x 18	185	3	18	98,5	-	137	336	13
80	80	180	68	138	160	8 x 18	200	3	20	109,5	-	148	336	17
100	100	190	83	158	180	8 x 18	220	3	20	125	-	165	336	26
125	125	325	120,5	188	210	8 x 18	250	3	22	152	262	192	336	43
150	150	350	145	212	240	8 x 22	285	3	22	173	305	217	500	61
200	200	400	180	268	295	12 x 22	340	3	24	215	389	265	500	111

(*) Dimensions in mm

Actuator connection

DN	ISO 5211	B	C	ØD	n x F	I	J
15	F 05	11	10,5	50	4 x M6	M10x1,5	8
20	F 05	11,5	11	50	4 x M6	M10x1,5	8
25	F 05	13,2	14	50	4 x M6	M12x1,5	9
32	F 05	13,2	14	50	4 x M6	M12x1,5	9
40	F 07	19,5	20,5	70	4 x M8	M18x1,5	14
50	F 07	19,5	20,5	70	4 x M8	M18x1,5	14
65	F 07	20	21	70	4 x M8	M22x1,5	17
80	F07	20	21	70	4 x M8	M22x1,5	17
100	F 10	23,5	24,5	102	4 x M10	M22x1,5	17
125	F10	24,5	25,5	102	4 x M10	M22x1,5	17
150	F10	28,5	29,5	102	4 x M10	M28x1,5	22
200	F12	34	31	125	4 x M12	M35x2	27

(*) Dimensions in mm

GENERAL CHARACTERISTICS	Fig.156/154 Series SFF	Split Body	Floating Ball	Full Bore
DESIGN STANDARDS				
Valves design	EN 12516-2			
Body design	EN 12516-2			
Shell thickness	ISO 17292			
Flanges	EN 1092-1			
Face to face dimensions	EN 558-1 Series 27			
Actuator mounting flange	ISO 5211	DIN 3337	EN 15081	
Shell finishing quality	MSS SP 55			
Marking	EN 19	CE - PED		
TESTS AND CERTIFICATES				
Quality Assurance	ISO 9001			
Pressure testing	ISO 17292	EN 12266		

Torque Values in Nm

VALVE SIZE	AT DIFFERENTIAL PRESSURE		VALVE SIZE	AT DIFFERENTIAL PRESSURE	
	16 bar	40 bar		16 bar	40 bar
DN 15		8	DN 65	41	
DN 20		12	DN 80	71	
DN 25		14	DN 100	119	
DN 32		22	DN 125	190	
DN 40		27	DN 150	220	
DN 50		50	DN 200	450	

Kv Values in m³/h

DN 15	DN 20	DN 25	DN 32	DN 40	DN 50
20	40	75	130	170	270
DN 65	DN 80	DN 100	DN 125	DN 150	DN 200
550	1000	1650	3000	4200	9000

PTFE SEATS

Pressure-Temperature

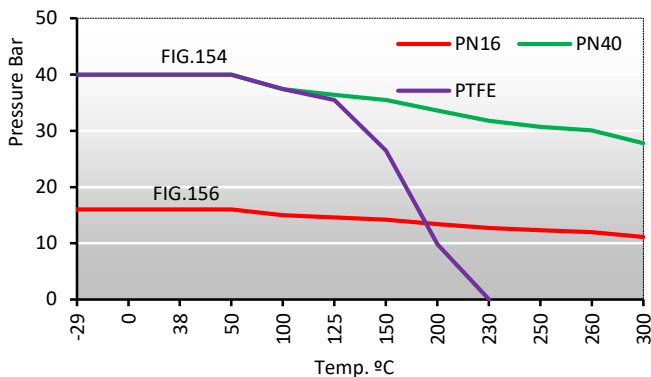

For 1.0619 only.

Pressure-Temperature

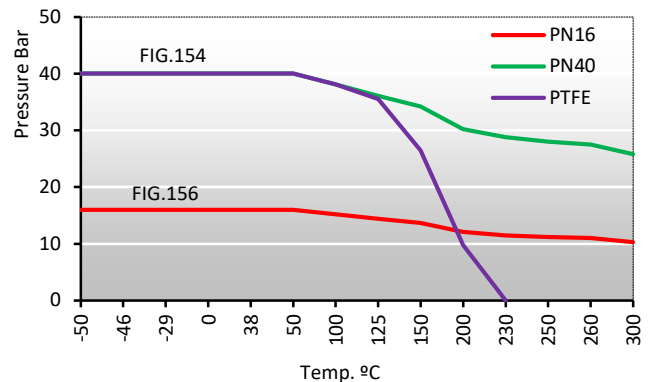

For 1.4408 only.

For other materials consult EN 1092-1